

Vladimir Markovic

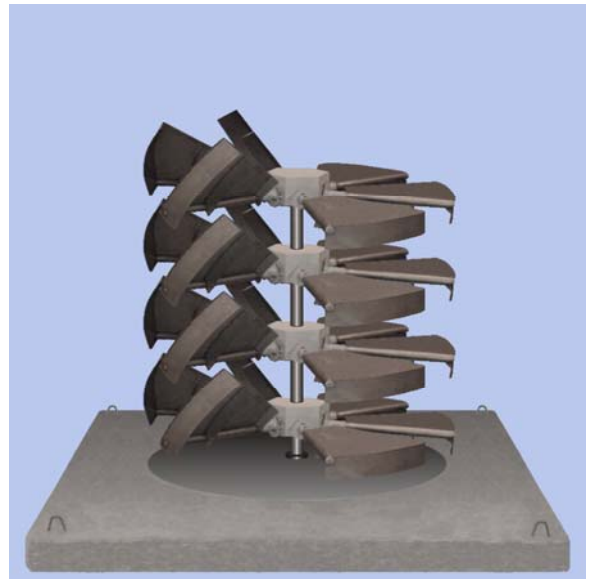

Logic, explanations and math of SP units 2010/2011

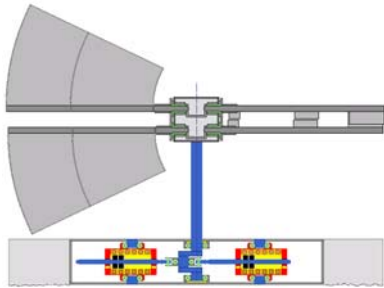
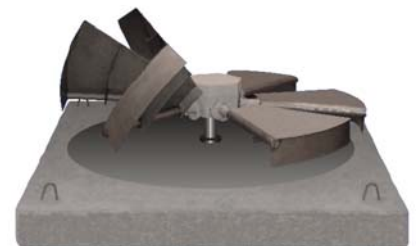
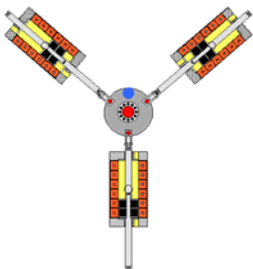
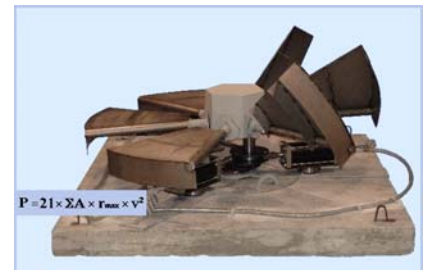

Written in Ljubljana, 16.10.2011

SP – A NEW APPROACH IN WATER TREATMENT

All people who are involved to the problems of natural sources and human environment will probably agree that after quality of air and atmosphere, the second most important natural element is clean, drinking water. Not only due to our needs of drinking, because the most of other living creatures and vegetation could not survive without water.

Today regarding all known facts it is clear, that there are two main problems connected to water: complete quantity of existing drinking water is on nearly all continents big enough, but regarding specific needs – specially on the poorest continents like Africa, the most of Asia and many parts of Latin America, displacement of available water quantity is definitely not acceptable and it is not offering simple, cheap and easy solutions for serving the most of needs for common use and specially not for needs of irrigation. On other side in medium or highest developed countries the most of water is polluted due to industrial activities, but not less important are just classical organic pollutions as result of concentration of human population in big urban areas.

Many years ago as professional inventor I was asked from some people which were involved in mentioned problems to try inventing and creating some new system, which would be able to solve problems of easier water displacement, but on the cheapest possible way and without opening a new energetic or ecological problems on other important parts of environment.

After nearly 20 years of activities on that field, I find out technical solution, to produce submergible unit, which should be placed on the bottom of every – even smallest and slowest river. My idea was, that complete unit uses part of hydro – dynamic energy of slowly moving water masses as driving source and makes possible that proper device pumps and deliver part of the water to the areas where it is needed.

It is known fact that quantity of theoretically existing hydro - potential power in all flowing waters is incomparably higher, than potential water energy which we are exploring today. Every new demand for further exploitation of this potential energy is connected with extremely high investments because available technology requires a local high energy concentration which means construction of water dams, artificial water - storage lakes, etc. Therefore it is very clear that also in the future we won't be able to place those installations anywhere we would like to have them.

Due to above mentioned problems, since century's engineers are trying to find appropriate technical solutions for the most efficient method to explore at least part of the potential energy from slow flowing waters. Water mill wheel was the first system that worked. Number of that kind of water mills, was in early Middle Ages only in England 5.624 and in whole Europe the number was larger than 50.000. But their relatively low efficiency was never high enough. Reason for that is in fact that it uses only upper layer of water stream, whose characteristics are totally different from entire water current. All described facts tell us that for much bigger efficiency we must perform our exploitation of dynamic energy of slow water current, in biggest possible depths. Based on described laws of Physics I started to think, about inventing turbine which "behave like barrier", and which could be fixed to the bottom of the river to exploit at least a part of that extreme energy. At the beginning I made myself clear that driving - active part or "turbine" can not be shaped on the way like classic water or even wind turbines. Without possibilities to increase local speed of water and

considering that hydrodynamics and aerodynamics are totally different by their effects, problem to be solved was definitely not small. So, I designed a system in which active “wings” shall be shaped like very big surface “barriers” to water stream but on opposite side of the turbine they will automatically turn against the stream – the smallest possible face. On described way, we received extremely large leverage on active side of turbine and very small (16-28 times smaller) on passive side of turbine. At the same time, due to known reductions of efficiency on classic turbine systems caused by speed difference between speed of media and speed of turbine, our design allows to the driving media to produce incomparable longer time of active pressure on each propelled wing with small speed difference between speed of water and rotational speed of wings.



$$N = \frac{V}{O \times 2\pi}$$

N = number of revolution/minute

V = water speed (meters/minute)

O = circumference of turbine (meters)

Such turbine – as presented on picture above must always turn much slower than speed of flowing water is. This means that its circumference speed – even without transferring of energy to other device – is always essentially lower than linear speed of running water.

Form for calculating (N) – number of turns of such turbine against speed of running water is shown beside the upper picture. The circumference speed of such turbine is couple of ten times lower regarding speed of water and that makes possible that each molecule of water, which presses on lifted wing of the turbine is relatively long time applying its pressure effect. Treating water at normal temperature as non squeezable media, we can conclude that molecules of water which actually perform dynamic pressure on every lifted wing of turbine do not press it individually, because from the direction of water flow, presses almost endlessly long chain of following molecules (and kinetic energy). Described case is not valid for known (classic) turbines, because in their case, pressure between the same molecules of running water and driving wings of the turbine can last only couple of hundred times shorter time. Also, this effect causes only partial change of direction of the flowing water and does not cause direct or significant reduction of local water speed, which is in Physics manifested in phenomenon called **Stagnation pressure**.

Stagnation pressure in Physics is clarified as pressure (or by calculation as Force), which is caused from horizontally running water on plain barrier inside of water stream (usually on surface of 1 m²). How enormously high is **Stagnation pressure** we can easily understand from the fact, that all under water carriers of the bridges are always rounded against water flow, because in case of their flat surface they can be easily demolished. On similar way, Energy which effects on wing of classic (and quickly rotating) turbine is couple of ten times lower than Energy which several times longer time has effect on much larger surface of slowly movable wings of SP turbine.

WATER, WATER, WATER

Water has been the emergence of human civilization, the basic prerequisite for survival and it courses an extremely serious problem, especially in underdeveloped areas of the planet. Due to pollution and industrial needs, even in highly developed countries, water is causing huge annual investments, which significantly exceed the annual investment for new energy sources.

Think on known data about how many tens of tons of water we spent for production of each tone of steel, how many tens of tons for each ton of other metals or synthetic materials. How many people are aware that production of each kilogram of beef consumes unbelievable 16.000 liters of water, production of each liter of milk 1000 liters, 40 liters of water we spent to produce each tinny cut off of bread or whole 140 liters of water for one cup of black coffee! So, conclusion is that the answers for survival of entire human civilization are not a food, raw materials or energy but in foundation of their origin – in water.

According to official data on the websites of several international organizations as FAO, UNESCO, UNICEF, UNDP, USAID, EUAID etc., the needs for new water supply investments yearly reaches around 200,000.000.000 (billion) dollars – just in less developed countries. In whole world, total annual investments for water-supply are approximately 7-8 times higher.

After installation in the underdeveloped areas of Africa, Asia and Latin America, the SP devices offers completely free delivery of water in distances even up to 100 km from water sources. In such cases we provide initial pressure of 10 to 20 bar but in combination with SG generators where every second unit is directly producing electric power. Then, inside of water pipe line we place also power cable that will bring electricity to the end of the pressure delivery to drive additional electric pumps for further transport of water.

According to UNICEF records, in whole world we have for more than 2 billion people living without permanent or available water resources. So, they are forced to carry with their own muscles a minimum of water required daily at a distance greater than 7.5 km. Further 1.8 billion people have permanent access to water, but of very poor quality (not suitable for drinking). With supply of clean, good quality water are provided even less than 2.5 billion inhabitants of our planet.

The largest consumer of water is the world's agriculture (ca. 70%), industry (ca. 20%) and individual consumption (ca. 10%). We have some exceptions (for example Belgium) but a global data are correct. And what will the world's water consumption this year: Almost exactly 3,362.000 billion litters (three million three hundred sixty two thousand) billion litters.

With natality, which is two times higher than mortality, consumption of water for every 20 years – will be doubled. In the next twenty years this means a doubling of today's pumping capacity for water supply of infinite "thirsty" humanity.

DETAIL EXPLANATION, HOW SP UNIT USES HYDRO – DYNAMIC ENERGY FROM SLOWLY MOVING WATER

To understand how system works you must understand that our driving “wings” are operating always in pairs – two of them on the same axle. Both wings (for example 12 and 12') are fixed on the axle 13, but on such way that one wing is fixed on the axle horizontally (12') and opposite wing (12) is fixed with inclination of approx. 60°.

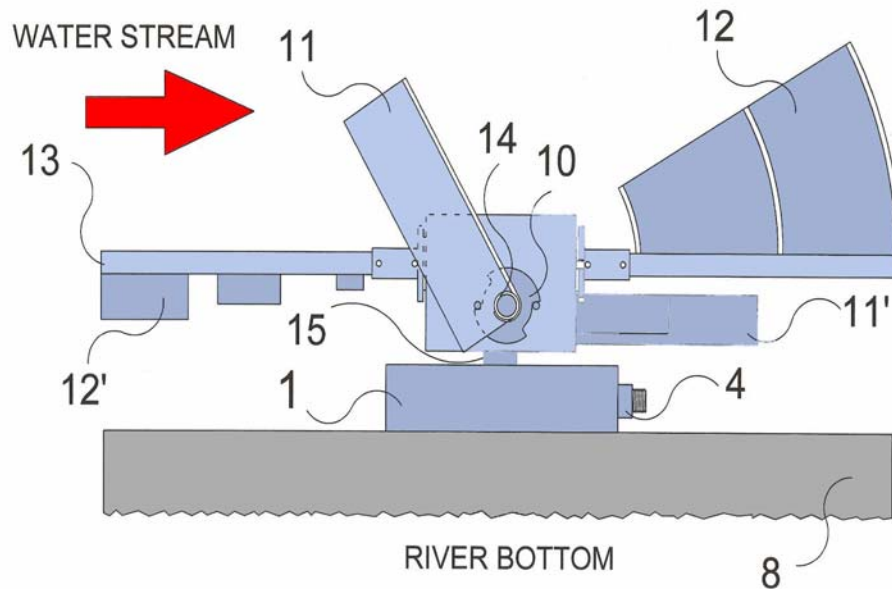

Therefore one side of such propelling system is always turning to the water stream the smallest surface and the second side (wing) is always turning to the water stream very big surface. When complete design turns around vertical axle for more than 180°, water stream is pushing down previously lifted wing and lifting up the opposite - previously horizontal wing.

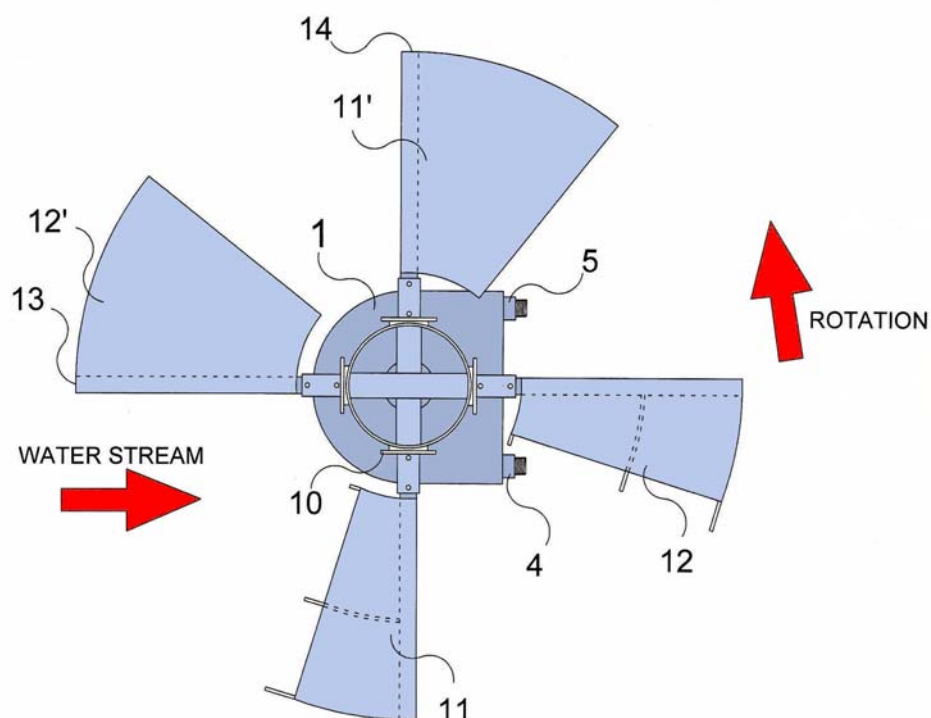

Described designs we made in more prototypes with 4 and 6 wings and we already measured extremely high efficiencies comparing anything known or existing designs up to these days.

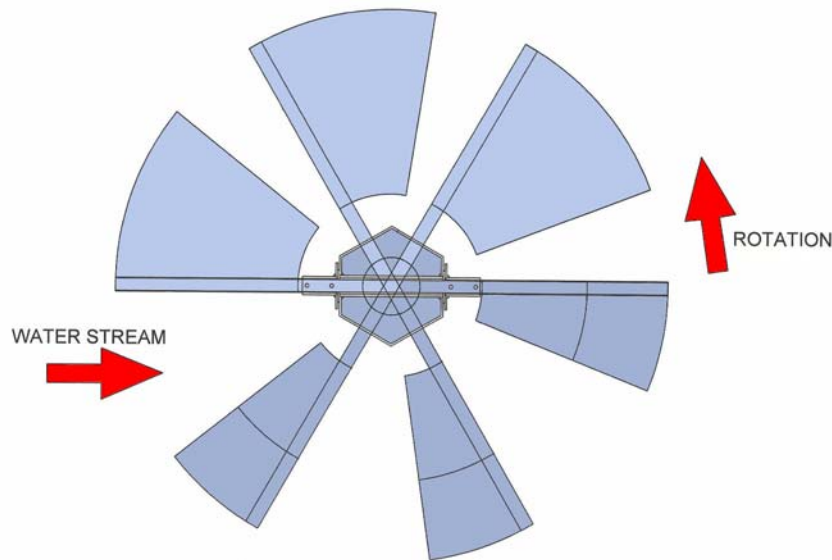

Up to now we made more designs with piston pumps, membrane pumps and very inconvenient centrifugal pumps.

Regarding question about possible difficulties with our SP units regarding usually present pollutions, garbage peaces, parts of vegetation including very big peaces of trees, timber, gravel, sand, etc., here are the answers:

a). Mentioned problems must be treated very seriously only in the case if (and when) SP unit would be stopped with rotation – what is practically impossible. During rotation there are on propelling wings two movements: (a) movement coming from global (radial regarding water flow direction) rotation because of which water can place larger garbage peace on the wing – on side from water flow direction. But, when complete turbine turns for 180 degrees the same power of water stream will push the garbage peace down and away from wing or wings. Here it is to remember that during rotation, on the SP rotors we can easily measure extremely large leverage which is on exterior diameter of smallest SP 16 in range of 1,2 tons and on SP 70 in range of 11 tons ! (by water speed of 2,5 m/sec).

b). Second element which is realizing “self cleaning” of propelling wings is their internal movement (for 62 degrees) – up and down - because the garbage part which is attaching the wing in upper position could not remain in the same place also in lower position of the wing. Simply, power of water stream will push it away. Specially, when we combine both a) and b) mentioned movements of the turbine and of the wings.

Treating SP propelling turbine statically has no sense and in such caseyes, problem is endlessly big. Only we could not find the reason for placing of blockaded SP Turbine in the water.

Our designs are Patent protected with priority of National – Slovenian applications and expanded with valid PCT applications (Patent 22869 from 31.03.2010; P 200900391 from 21.12.2009 and PCT/SI2009/000038 from 24th September 2009).



The first prototype from early development



The second prototype with 1,6 m diameter

Several years ago, (due to centrifugal pump) the second prototype was able to deliver only 1 litre per second of water based on 1,2 bar of pressure.



For example, instead of submersible water pump, we can use also submersible air pump which must have attached the inlet hose for air. The opposite end of this hose must be fixed somewhere on the coast and out from the water. In that case, SP unit is sucking the Air and pressing it in very small bubbles on the bottom of the river where deficit of the oxygen is always the biggest – causing a very quick “burning” of the mud and all kinds of organic pollutions. On described way we shall be able to “turn back” to our rivers a normal “health” which was taken by too high quantity of organic sediments on nearly all bottoms of slower rivers.

Basic idea for higher capacity of irrigation is to connect outlets of more SP units to the bigger diameter of main pipe. This can be done by means of connecting 50, 60, 100 or even more hundreds of SP units to the main pipe with diameter of up to even 2000 millimetres. In such case and specially if we combine such main pipe line with inside Air injecting system (produced from some of connected SP units), we shall be able even to combine consumption of water, transport of and simultaneous cleaning of water from organic pollutions. On the following picture, you can see some other possible application in use of SP units:

On the most places of the river bodies the land configuration denies possibility to build a dam and lake. This problem can be solved with submergible accumulation pipe on which we attach convenient number of high capacity SP units. On other end of such "reservoir pipe" a standard Pelton, Francis or other turbine and generator are to be connected. The costs of such installation are still significantly lower than usual (construction of the dam and lake) and the effects can be even much greater, because the pressure pipe can deliver into turbine up to 10 Bar or higher pressure what is equivalent to water falling from almost 100 meters high dam! Accumulation pipe is to be placed on the side of the river bottom and turbine and generator on the coast near the river. **So, we can install Hydro Power Plant nearly everywhere we want – spending several times lower investments !**

By double wings SP units shown on the right picture, the Power capacity is more than two times larger. Number of needed SP units depend from speed of water stream and can be easily calculated for each installation between 1 and 10 MW of Power but under special conditions, also much stronger installations are possible.

From research and development we learned that the market will require more dimensions of SP single and double units:

SP "hobby" unit with capacity of 1 liter of water per second and with a diameter of 1.6 m; SP unit with a capacity of 3 liters of water / second and diameter 2.4 m; medium unit with wings diameter of 3.6 m; and large SP units with 5.5 m and 7 m of diameter with single pumping capacities from 17 to 44 liters / second.

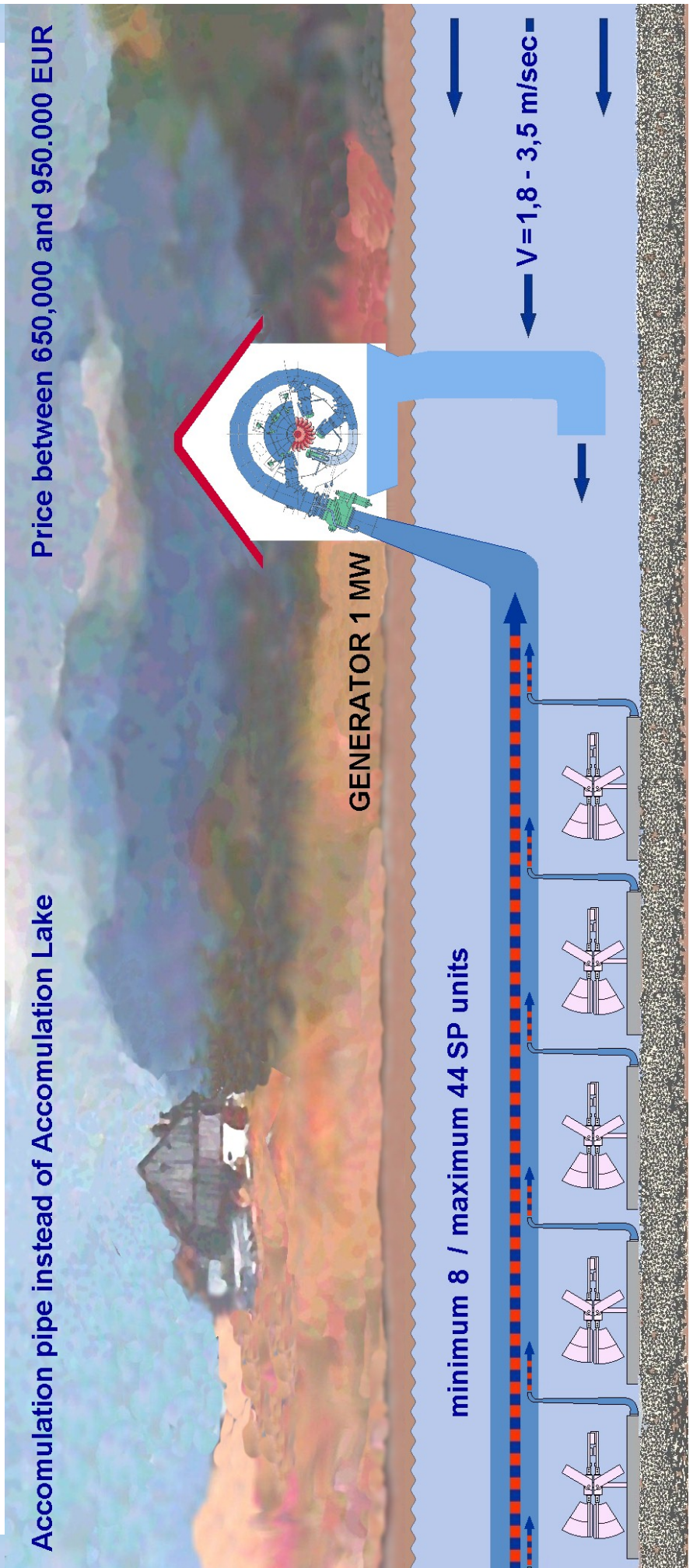

WHAT COURSES THE DIFFERENCES BETWEEN KNOWN TURBINES AND SP TURBINES?

The SP Turbine must be placed at the bottom of river and obtains propelling energy from up to now, never utilized, part of the water power. Submersing the SP Turbine close to the surface of the water stream rapidly reduces its efficiency.

The SP Turbine consists of high pressure pumping parts connected to horizontally placed concrete foundations and integrated with the horizontally placed turbine system with more pairs of driving blades of which one side (one half) constantly turns its largest surface against the water stream and the second half turns its many times smaller surface against the water stream. This causes a simultaneous rotation and propelling of high pressure pumps for water delivery.

SP Turbine stands for “Stagnation Pressure Turbine” which uses Stagnation pressure for the highest possible efficiency to propel pumps or electric generators.

Theoretical calculations for known Waterwheels are saying that maximum of their efficiency could not oversize 15 %. Generally speaking it is correct. But from our calculations it is to understand that efficiency of SP Turbines is much higher. Therefore it is wrong if for calculations of SP turbines we are trying to use formulas which are in use for classic Waterwheels. Reason ? Stagnation Pressure is on classic Waterwheel not present ! Even more wrong is to use calculations for pressure pumps with needs to calculate Power of SP Turbines. Also, if we use formula $P_h = q \rho g h / (3.6 \cdot 10^6)$ which generally calculates the power needed for a pressure pump, result will definitely not give us data of SP Turbine Power.

For example, with the same speed of water (1.7 m/sec – present of one of our movies), the number of revolution of this 2.4 m diameter SPT is practically the same (3,1 Rev/min) when pumps are attached - or when the same SP Turbine runs without pumps! The reason for that is in the fact that with so small ballast from all 3 pumps (each working only with one side of chamber), with a pressure of 1,1 Bar, used power is close to 200 W. But this is not the whole Power of propelling Turbine because even without any ballast, by mentioned speed of water, this Turbine could not get larger number of revolutions / minute ! For example, measured by proper (alternator) ballast, the same Turbine is by water speed of 1,7 m/sec, offering 2,7 Rev/min and 1,4 kW of Power !

Generally, in hydrodynamics, rotor resistance yields completely different results on known turbines as opposed to the SP Turbine. The reason for that is in Stagnation Pressure which has a very small influence on all known turbines but even in Bernoulli formula for Stagnation pressure, Static pressure (Ps) must be directly added to resulting Power. Even more important is that with classic Waterwheels water does not react as a non-squeezable media because it has a free space to move itself to “up” – to direction of very squeezable air. But, at higher depths movable water reacts almost like a “rigid” force.

The difference between Stagnation Pressure on the top of the water stream against stream in larger depth is to be understood with example: if on the floor we try to push some heavier ballast with steel rod (and we are successful) or, if we do it with rod made from soft rubber (which will be banded and quizzed). So, on the top surface, water stream is pushing barrier with a “rubber rod” and in the depth is pushing the same barrier - with a rigid - “steel rod”.

RENEWABLE, ALTERNATIVE OR CLASSIC ENERGY SOURCES ?

Dealing with problems regarding renewable energy sources it is very typical and today, the most of efforts refer to exploitation of solar or wind energy. Despite all advantages which moving water masses are offering, efforts to increase exploitation of energy from water stream are today very small even when we know that constancy of exploitation during all 24 hours a day is by water nearly ideal. By the same speed, water has almost 800 times larger pressure on the square meter of flat surface in comparison with air (wind) pressure, etc.

Reason for described situation is very simple. Until today, exploitation of energy of moving water mass was limited on small number of technical solutions: Since centuries known water mill wheels and nearly century known water turbines. But, both mentioned solutions have enormous disadvantage, because their efficiency increases only when water speed is several times higher. That fact enlarges installation costs for several ten thousand times forcing us to create artificial lakes with water dams for local water speed enlargement. The same time, it is known fact that due to geo-physical characteristics of the soil, we will never be in position to place and build dams and artificial lakes on the most location we would like to exploit energy from the movements of water masses.

Water millwheel was the first system that worked, but it has relatively low efficiency. Reason for that is in fact that it uses only upper layer of water stream, whose characteristics are different from water current near the bottom of the river. Here we are talking about simple fact that water (in comparison with air) is not squeezable medium. But this fact refers only to water in the bigger depth because on the top level, coming to the barrier, generally not squeezable water is sliding to the upper direction of the squeezable air and completely loses characteristics of not squeezable media. For instance in the bigger depth, on every square meter of fixed barrier, water causes dynamical pressure, which is (at the same speed) app. 800 times larger than wind pressure on the identical surface of barrier! In that case water, on surfaces of the water wheel wings, does not apply stronger effect of so called **Stagnation pressure**, which always occurs when water hits the barrier.

The best way to understand how big disadvantage is caused by described facts is to be understood only after we consider a very simple physical fact that energy which is present in one mile length of slowly moving river is exactly the same as energy on the same river accumulated in one mile long lake before dam! So, extremely expensive dams and lakes we need only because all known turbines could not offer higher efficiency without much higher water speed - locally increased by tunnels in the dam. Now, if we compare all common river lengths with lengths of all artificially made lakes with dams, comparing whole World, we come to the fact that proportions are larger than 10.000:1 in favor of common river body lengths. This means, that with proper technical solution for consumption of energy from slowly movable river streams, if solution would be cheap and easy to install and use, we could overcome complete worldwide energy received today from all classical hydro - energetic power stations.

Treating theoretical background of power and efficiency possible to be reached by SP units I meet many problems regarding classic known calculations and formulas made for known turbines or propellers. At the first place I recognized that we must deal only with kinetic energy of moving water masses without using known calculations which are nearly always connected with measuring of flow and efficiency inside of the pipe.

Second reason why usually known formulas (Bernoulli or other) are not appropriate for our turbine is in the fact that by known turbines or propellers radial speed of the turbine is always very high. This is the main reason that **Stagnation pressure** effects are by classic turbines very low, what is completely different when treating our SP turbine on which the highest circumference speed is always much smaller than speed of the water.

The third reason for lower efficiency of classic turbines is in the fact that due to high RPM, the back sides of all wings are causing the braking effects because they are pushing water sidewise – out from its straight moving lines. By SP unit wings this effect is opposite and the same time when water is overtaking each lifted SP wing it is causing also part of propelling power on its back side.

Apart from mentioned and always present part of Stagnation pressure which has very high influence to efficiency of our SP unit, it is very important to remember that on the same way as water is not (practically) squeezable it has some characteristics which shows also its resistance to ductility. This practically means that in open current water area which is driving SP blades (wings), water propelling power is not limited only on the surface of lifted wings but also on slightly wider area (for approx. 1,3 times) of the water stream. Additionally, regarding higher stream speed (than blades turning speed is), it is to be recognized that water is simultaneously propelling all three active SP blades at once. This is causing important effect of actual enlargement of active driving surface for approximately 1,8 times!

All three mentioned facts are basic “secrets” of so high efficiency of SP units which many of known experts for classic turbines are simply, not able to understand. By most classical formulas for calculating turbines power - even by formulas composed by the biggest experts on the field of Physics – inside of formulas are included data about turbine efficiency. Results of such calculations are not even theoretically correct because efficiency of any turbine is completely dependent from actual conditions of water quantity, pressure and speed. Therefore, when water quantity and water stream are changed we can never be certain for how much efficiency of turbine is changed and calculations are becoming a total nonsense.

Treating Stagnation pressure - even the exact and deeply educated people are not actually aware of how extensive and powerful it is. Therefore we must clarify that Stagnation pressure calculations are actually based on the Energy Density of Flowing Water - when the water is treated as incompressible medium. EDFW formula is as follows:

$$\text{EDFW (kW/m}^2\text{)} = 0.5 \times v^3$$

Presented means that every square meter section of river flow carries a power:

- 0,5 kW – by water stream speed of 1 m/sec;
- 1,7 kW – by water stream speed of 1,5 m/sec;
- 3 kW – by water stream speed of 2 m/sec;
- 6,8 kW – by water stream speed of 2,5 m/sec;
- 13 kW – by water stream speed of 3 m/sec;
- 21,4 kW – by water stream speed of 3,5 m/sec;
- 32 kW – by water stream speed of 4 m/sec.

All mentioned values are related only to Water Density and never to Hydraulic Power, Power of some turbine or passive resistance of barrier on which water is pressing.

Considering a fact that on SP drawing wings water flow at the same time always presses at all three active (lifted) wings, we can see that on the largest SP/SG device water is simultaneously propelling almost 6,5 square meters of surface, which are on double wings devices (see page 18) even increased to almost 13 square meters!

Everything described so far indicates that with water stream speed of 3 m/second and built 10 pairs of double wings, each double pair (with double wings) can offer 130 kW of Power and the whole assembly (shown on page 19), theoretically can offer up to 1.3 MW of Power. Unfortunately, the lowered (horizontal) wings are braking rotation and practically received Power could not exceed 1 MW.

In modern physics to calculate the Force from Stagnation pressure we are using a math from Bernoulli equation (for incompressible media):

$$P \text{ (Pa = 1 N / m}^2 \text{ = 1 Pascal)} = 0.5 \times \rho \times v^2 + P_s \text{ (Pa)}$$

where: ρ = density of water in kg/m³ and P_s = static pressure

If we perform calculations of Force by Stagnation pressure with the last mentioned form, it looks even larger than calculated by other formulas. But, in our case SP wings are not stopping the water movement completely and that is a reason that this calculation is not realistic and correct.

It is important to know that even that calculation shows that extracting of Power from the upper water layer gives significantly worse results, since at the top of the stream static pressure do not exist at all and it is present only in lower layers of water. On the top layer water react like compressible media and reaching the barrier it withdraw up - to the direction of fully compressible air.

Regarding mentioned reasons and mistakes coming from efficiency data inside of formula, in our formula we are dealing only with known parameters of physics, and with basic dimensions of used SP unit. This means that results are always correct - even in cases when factors of outer conditions are drastically changed. After many measures and calculations we found out that correct formula for calculating power of our SP unit is:

$$P = 21 \times \Sigma A \times r_{\max} \times v^2$$

P=power in watts (W)

ΣA =surface of all installed blades (m²)

r_{\max} =exterior radius of blades (m)

v^2 =water stream speed (m/s)²

Noted formula is proved by comparing it with practical and measured results. We must also consider that sometimes each blade could not cover complete surface of 1/6 of circle. Reason for that is in often customers enquiries that complete unit must operate in very shallow water. All this means that for example seven meter diameter, single wing SP unit (without reducing blades) must operate in at least 3,6 m deep water, but in that case, with water speed of 3,5 m/s it can deliver nearly 35 kW and by 5 m/s around 69 kW of constant power. With double propelling wings, results are doubled too.

Regarding all mentioned we are still opinion that producing electricity, our SP units are nearly ideal solution for the category of "Pico" generators, where we intend to remain on the powers up to 20 – 70 kW, but it is definitely a fact that also much larger SP units can be designed with possibility to offer more than 100 kW based on constant power. Finally, our last calculations are showing us that here locally and based in 20 years of exploitation time, we can locally produce and install in water "Pico" power units (only 20 kW of constant power) based on price of only 0,0075 EUR per kWh. It is very possible that someone will not recognize real meanings of that price which is actually much lower than exploitation price for kWh reached with larger photo cell units or medium big Windmills! Even more, this price is for 8 to 14 times lower than valid prices are for electricity from public nets in different EU countries.

Alternative Energy: Confusion of understanding or understanding of confusion

Since many years we have been facing a problem of confusion in understanding the actual physical properties of so-called "alternative energy sources". General Physics teaches us that Energy is the cornerstone of the whole Nature, because it is a primary form of masses that surround us, and from whose material we are created. Best show ever-present Energy we can get through the treatment of AGP - Absolute gravity field (by Einstein), which is always something bigger than a recognizable Space, is connecting the entire Universe, and consequently it is recognizable also in endlessly big number of other Energy forms. So, the total mass of the Universe and everything is made of Energy apparently derived from the primary energy of the Universe - Gravity.

So, first of all let's see what "alternative energy sources" are in Nature and if they exist at all. After a short analysis we can see that basically it is always one and the same primary Energy that is manifested by the Gravitational force of our planet and in the second case which is formed on a basis of Sun's gravity due to the presence of Solar radiation. So, here is always Gravity and there are not existing any kinds of new or "alternative energy sources," but only **alternative methods** of exploitation of always the same (Gravitational) Energy, which directly or through the consequences of its action, has for long time been exploited by the traditional known methods.

In addition to conventional methods of converting Energy into electric power, which often carries environmentally harmful consequences, in the last decades a lot of efforts were made on the production of electric energy from the so-called "alternative sources". But actually in the Nature there is nothing like "new energy sources" but just different forms of always the same Energy. For such different forms of Energy we are forced to use new or alternative methods of "extraction" or generating electricity but in the fact, electric power we are receiving is always coming from the same energy source which is the base of the existence of our Nature in which we live. Therefore, the analysis below must first be granted in three groups – regarding the "nearest" Energy form which one we are transforming it to electric power:

1. Direct conversion of solar energy into electricity (photovoltaics),
2. Indirect conversion of solar energy on earth (through the creation and utilization of wind power) and through bio-technology,
3. The energy gained by the gravitational forces of the majority of the Earth gravity (through the movement of water masses).

In the first group we can find known photo cell systems for directly converting solar energy into electrical voltage. Due to the relatively low value of the total solar energy per square meter, low-efficiency of photovoltaic panels and their high prices kW hour of electricity supplied, is for many times more expensive than the price of conventionally produced electricity. In addition, its supply is not permanent (night / day, cloudy weather, etc.) and installation is visually quite unaesthetic.

In the second group are very expensive and environmentally and visually not acceptable windmills whose kilowatt-hour is nearly ten times more expensive than electricity from the grid. Their power supply is also quite irregular.

Bio-electric technologies will be really useful when will be in position to convert biological waste and garbage into electricity. Using it to convert to electricity any kind of potential organic food is unacceptable.

In the third group remains the cheapest electric power Energy that is obtained by means of gravitational movements of water masses.

Dealing with the third method for producing electricity we are always meeting a lot of mental errors from the classical education. It is a mistake when we think that electricity is actually obtained from kinetic (motion) energy of water. Due to the (many times) relatively small sizes of most river streams, it is giving us impression that from them we are finally limited to get any larger amounts of electricity.

Although we know that on every square meter of intersection of water stream, water is carrying a few hundred times more energy than wind at the same speed, it seems that relatively small quantity of water in the rivers is limited us to get more Energy. But in fact, we are limited only in the construction of large reservoirs like lakes and dams for which formal knowledge is teaching us that they are the only solution.

The problem is in misunderstanding of the Energy, which is obtained through the movement of water masses. On one way all we agree that moving of water is coursed due to Gravity. But at the same time, the most of us are forgetting what is a basic source: Gravitational Energy which can produce kinetic energy on any kind of mass or - water itself. Wrong understanding is even that kinetic energy of moving water masses is coming from water because it is coming from Gravitational Energy and water is only transmissions source. All understandings except that - are wrong.

Why? Total energy of a stream we can check measuring movement of water through the vertical section-cut of the riverbed. So, if the cross-section and water speed are smaller, according to both reasons the total energy of the stream will be smaller.

Measuring the flow value of total energy of a smaller river stream ca. 10 m before large mill wheel placed in the stream and ca. 10 m after mill wheel will give us very unusual but serious absurd: Although the mill wheel is propelling electric alternator that produces 10 kW of energy or more, the water flow value measured before the mill wheel is completely the same as measured after the mill wheel! This means that the kinetic energy of water masses before and after mill wheel remains exactly the same.

According to the laws of energy conservation, Energy can not be spent or nullified. It also can not be obtained from 'nothing'. So, Energy can only be transformed from one form to another - completely or partly.

So what we got: If the energy of water flow before and after the mill wheel is exactly the same, where the mill wheel is obtaining the energy for its rotation? If obtaining Energy from kinetic energy of water masses then velocity of water in the stream must be reduced, but exact measurements are confirming that this is not a case!

Opinion of even top experts on hydrodynamics saying that there is such small power consumption by the mill wheel that is not measurable, but they are wrong. Why? For example, in the above-described small stream with some meters of distance between each other, we can put 10, 20 or even 100 mill wheels. If every one of them is propelling 10 kW strong generator we can obtain even higher total energy than exceeding the total energy of the stream. Even in that case, some meters behind the last mill wheel in the stream we measure the same quantity or flow, the same amount and velocity of water (i.e. the same energy of water) as we find it before the arrival of the water to first mill wheel. We can find described evidences in the concrete made channels for melioration, where are placed hundreds of smaller mill wheels with diameters and width of about 2 m and gaining total production of relatively high levels of electricity.

Speed of the water and its flow rate remains exactly the same before the first and after the last mill wheel! One Italian producer from Ravenna raises its mill wheels at a distance of ca. ten meters (see Figure 1) and in some cases of just 2 or 3 meters of distance from each other (see Figure 2). Despite all "classic" explanations, power received from each of them is exactly the same and water flow after the installations remains the same as arrival on the first mill wheel!



Fig.1-water wheels during maintenance



Fig. 2-water wheels in service

When I decided to transfer this title to the public, I was really disappointed when I realized that I would be forced to attach pictures and examples instead of only clear and clean mind. But, It is a case that – even for educated "experts" - only clear thought, calculations, or even physical interpretation - usually are not enough.

It is clear that between velocity of the stream and quantity of water on one side and mill wheel on another side, there are some reliable physical connections. It is also clear that, if energy of the water mass remains the same, mill wheel is actually getting Energy for its rotation – somewhere else.

Very similar to the encountered paradox we get even at big power plants (with lakes and dams), where under the assumption that the dam is not causing a water loss due to groundwater flow, measuring the river stream before entering the lake and after a lake and dam, we are measuring exactly the same energies of the river stream itself. So, from which Energy power plant is producing so big electric power if kinetic energy of river stream remains the same?

The described paradox I discovered at the early beginning of designing SP devices. Hydrology and other water experts, and a plenty of literature offered me a lot of answers regarding possible calculations of various parameters and calculations of particular turbines. Indeed, understanding the paradox described above remains unexplained. Here and for the first time I met explanation that because of high water fall inside of dam and the fact that Energy can be potentially increased with much higher water speed (what is typical ability of Gravity field), I recognized that also all hydro power plants are using a water flow just as some kind of “compulsory source” or “source for transmission” because all Energy they are consuming from Gravity field and forces which are forming a fundamental background of our existence.

But for more than two millennium years known mill wheel, where the speed and energy of water remains the same, is nothing clear or we must accept the fact that the Law of conservation of energy - simply said – here is not valid!

However, let us stay on validity of Law of Energy conservation. To understand the paradoxes described above without resources, testing facilities and due to total ignorance from professionals being active with Physics, Hydrology or engineering, I was forced to find out the most important answers by my own. Fortunately, I meet the answers only through close observation and analysis of seen effects. I recognized a known fact that liquid water on arrival at the obstacle placed in the stream - rises in the upward direction. OK, it is logical because water is relatively non-squeezable media and is retreating in the direction of squeezable air, above water top level.

Very similar to described effect I have noticed in the moment of arrival of running water on mill wheel paddle - in the moment when paddle started to sink in to the water. This effect - very similar to described before is perfectly logical and not very interesting. But at the initial observation, I recognized something much more interesting and much more important: Local rise of water level when reaching obstacle was after them immediately turned back on the previous level. But reaching a paddle of mill wheel, water level remains to be higher for much longer time, actually for all the time when paddle was shifted beyond the vertical shadow of the entire mill wheel cycle! So, under the vertical shadow of complete mill wheel some kind of “dome” was formed on the top of the water and if there was place enough on the sides of the wheel, “dome” was lower but inside of very narrow canal it was even visually recognizable! So, I find out the fact that lifting of the water (to up) was not caused only from mill wheel paddle when started to sink in to the water but also for all the time until each paddle was under the water level ! Consequently, all that means that paddles of a mill wheel are temporary changing the gravitational trajectory of the part of the water masses

lifting it (against Gravity) in to the vertical direction. Exactly this Energy which was needed for temporary lifting of water masses to up is the Energy which is propelling mill wheel inside of the water stream.

Soon after exiting the "vertical shadow" of the mill wheel, by act of Gravity, the water level suddenly dropped to the previous level and speed and energy of the total water stream remains the same - as they were before touching a first paddle (flap) of mill wheel. So, where the mill wheel, draws energy for its rotation? Actually by the Energy of Gravity field of our Planet. How? Simply speaking, disturbing inertial (nearly horizontal) trajectory of water masses but not with trying to stop it but to redirect a part of water to move vertically - directly against main Gravity effect - weight. Energy spent for lifting water masses to up is equal to propelling Energy which the mill wheel is receiving for its rotation.

Described also means that the classic and for centuries known calculation (via kinetic energy of water) for the mill wheels is not correct at all, nor gives the correct result - unless you continue to defend the bizarre claim that according to completely unclear reasons, the mill wheel has only 12% of efficiency!

Everything described above was in my mind when designing the SP devices. But, it was too early for all explanations and I introduced SP units based on only classic calculations and explanations which can be found on my website <http://www.izumi.si> . In the meantime, regarding a knowledge of the actual causes of the described phenomena, I designed many other forms and structures which can increase efficiency even by mill wheels but specially by new designs of apparatus that will allow conversion of much greater GRAVITATIONAL ENERGY to electricity - of course **with the help of water stream** – and not by exploring or extracting energy **from water stream**

Described phenomenon as well as at least a few other and similar occurrences, we deal in hydro dynamics enables us to several other, very important insights. These findings are very important as they confirmed my assumptions that even in very slow moving rivers we can install adequate systems to generate huge and for many hundreds times larger amounts of electric power, which will definitely continue to be the basic form of Energy for the public and general use.

Why is recognition of realistic facts about Nature so important also in described case? Simply, because without knowing them, one average hydrologist or engineer will never even come to idea that from relatively very small rivers it is possible to “extract” many kW of Power - if complete kinetic energy of water stream is very small. But if we explain to them that water stream is only transmitting source and realistic Energy we are extracting from Gravity, maybe they will be also able to create unbelievable and new abilities.

All this would be possible only under the condition that the educated part of mankind would not blindly accept all classic known theories and explanations – especially if they do not understand them.

SOLENOIDAL GENERATOR

At the end of the year 2009, we succeeded to develop, test and apply patent of new SG generator for production of AC tension with centrally inserted magnets, which for difference from commonly known generators for its activity does not need great number of revolutions from its driving source. By its technical design, each separated part is similar like impulse generator, which works on principle of hammer stroke or spring and were created and in use in laboratories shortly after year 1780, on the first place for gaining impulses of high electric tension. These tensions were gained when proper number of coils of solenoid, which had one or more windings with different number of coils, what made for scientists like Michael Faraday, Lorentz, Maxwell and others, job much easier when they studied fundamental laws of magnetic and electromagnetic phenomena. In subsequent periods, for almost a century, solenoid structures with embedded ferromagnetic core are not exploited for industrial purposes within the meaning of electricity voltage in solenoid for several different reasons, most of whom are set down the problems of low intensity, and in particular the sustainability of permanent magnets themselves that are moving created through an electromagnetic field to rapidly lose its magnetic density. The second problem was the fact that such a generator is not appropriate to create a constant tension, because on both ends we get change of the movement direction of the magnet and at the same time, to alteration of the polarity of inducted voltage. Following the introduction of today known voltage generator and a substantial improvement of the stability and sustainability of the magnets themselves, there have been many inventions and structures, particularly the smaller generating devices incorporating permanent magnets, which many of them are still found in regular use. However, in these cases, the magnets rotate and with their rotation induce formation of voltage, or current in the solenoid coils distributed throughout the periphery of the generator. Practical examples, which are today known in exploitation of solenoid coil with axially movable core, are most common in the use of modern actuator devices, as it is for decades much known anchor for switching on automotive starter and dozens of cases of solenoids equipped with a movable core for valve systems guidance. In the opposite direction, or for the production of continuous electric tension with the axial movement of permanent magnets mounted in the center of the solenoid, there are not any serially produced products in the practical exploitation.

Illustration: Side – section of one out of three segments of our new generator with double permanent magnets and six solenoid coils.

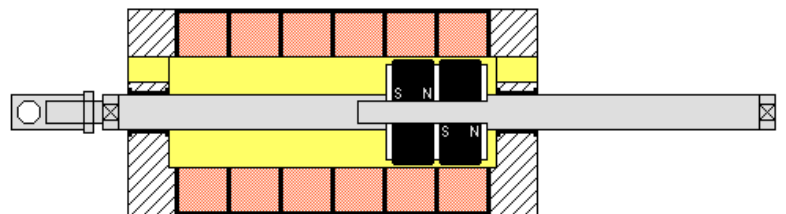

Technical problem, that the SG generator successfully solves, is based on the physical fact that in solenoid we perceive induction of electric tension even when having extremely slow axial movement of the centrally – installed magnets. By that, the solenoid coils developed electric tension, which depends primarily on the number of wire windings and when moving the magnet in one direction induces DC electric tension with properly oriented polarity and by axial movement of the magnet in the opposite direction, the polarity of the induced voltage also reverses.

This practically means that the continuous movement of the magnet back to front in solenoids induces AC electric tension, whose frequency depends on number of changes of the direction movements of the magnet itself. In described case will, by the minimum with consumption of electricity and density of magnetic field. Induced voltage depend primarily on the number of wire windings of the solenoids, and by increased frequency of movement magnets back – front - back will mainly grow the available electric current. Described characteristics are fundamentally different from conventional operating characteristics of the known generators, alternators or DC dynamos with permanent magnet, when by small number of revolutions are obtained many interruptions of induction and self – induction. However, despite this seems productive for the generators and dynamos, in fact makes the need for a relatively high number of revolutions of rotor, otherwise it is impossible to achieve sufficient electric tension, or each stator should have unacceptably high number of coils of copper wire which means even unacceptable diameter of design. At the same time on classical generators or dynamos, losses are increased due to transverse magnetic fields coursed by the laminar structure of their magnetic cores, which can not operate at all number of revolutions of the generator by at least approximately the same efficiency. Because of all this and many other well and long known deficiencies of the known generators, the basic idea of SG generator sought to construct a useful electrical generator, which in addition to those problems, it will also not have problems of magnetic gap between the rotor and stator and also with hysteretic losses in the generator plates and long magnetic path through the magnetic segments of the stator.

SG solenoidal generator eliminates quoted and solves the technical objects on such way, that rotating driving media via appropriately designed system always and at the same time eccentric and co-axial moves, three or more axes on which are attached permanent magnets – placed in the centers of three solenoidal housings.

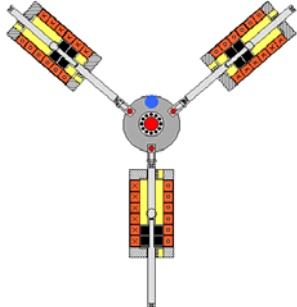

With the help of appropriate eccentric mechanisms, the SG generator have magnets on axles inside solenoids always placed in different positions, what causes that will never come in situation of simultaneous changes in the direction of movement of magnets front – back – front and there will never be a complete absence of induced voltage. Above all, the correct calculation of the magnetic densities and the number of coils of each solenoid or solenoids, a new SG solenoidal generator will explore the possibility of continuous and highly efficient generation of electric tension even at the minimum number of turns of driving media what will eliminate the need for the use of mechanical gearboxes or multipliers between the driving media and the main axle of the generator.

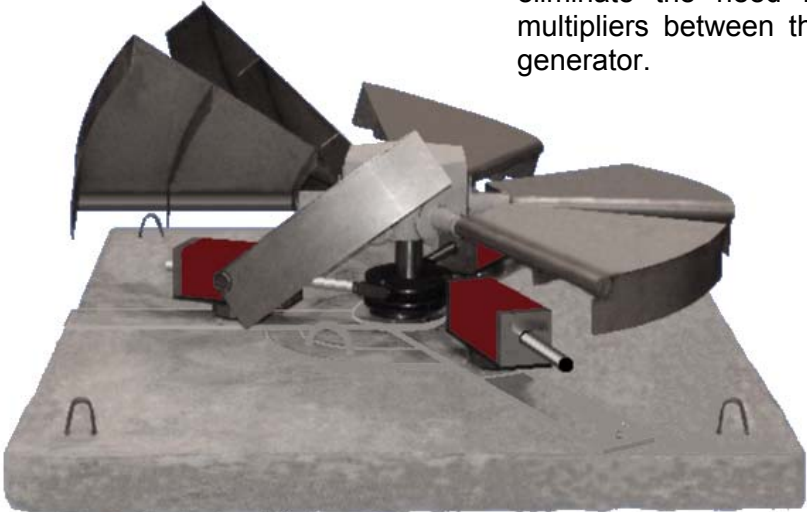

This should allow efficient generation of electricity even at two or even less number of turns per minute, without increasing the losses and at the same time allow the operation of even a hundred times higher number of turns.

Regarding everything mentioned above at the end of last year we started developing more prototypes of SG generator and we found out, that up to this days nowhere in the World something even nearly similar to SG generator was not invented, patented or designed. The most important feature of new SG generator is that its production is extremely cheap, because for example, 20 kW unit will cost in serial production much less than 1.800 EUR and even much stronger 70 kW unit will not cost more than 2.700 EUR. Even more important feature is very easy possibility of this type of generator to produce nearly constant electric tension between 2 – 250 rpm and only electric current and final power are increased by higher number of revolutions. Producing DC impulse power with nearly constant tension, which depends from requires, such generator is drastically reducing price of inverters for possibility to be connected directly to electric net system.

From descriptions of SP units you can find out that we are talking about quite unusual design, which uses only dynamical pressure of slow water current. Even more, by larger water speed, its efficiency becomes lower! Complete design is convenient to drive water pumps (for irrigation) or alternatively to drive directly submersible electric generator. It is also suitable for performing aggressive micro aeration, by which through hose is sucking air from the river bank and injects small bubbles (smaller than 0,2 mm) on the bottom of the river. That causes oxidation of organic pollutions and elimination of the organic mud, which is mostly present on the bottom of the rivers or the water dam lakes. In the following text and pictures you can see the explanations and principles how new self propelled pumps (SP) are working and nearly unbelievable possibilities of their use. Our design is working above all in slowly moving water, when stream speed is higher than 7 m/s, its efficiency even lowers.

Already in the early stages of prototypes of SP devices we have received much criticism about that, that during the operation of device under water, there is a continuous risk that floating dirt, branches and similar could block the operation of propelling pumps or generators. Therefore, when developing SG generators we take care of their protection or complete elimination of such possibilities - for SG generators as well as for pumps and other items that we drive with the SP devices.

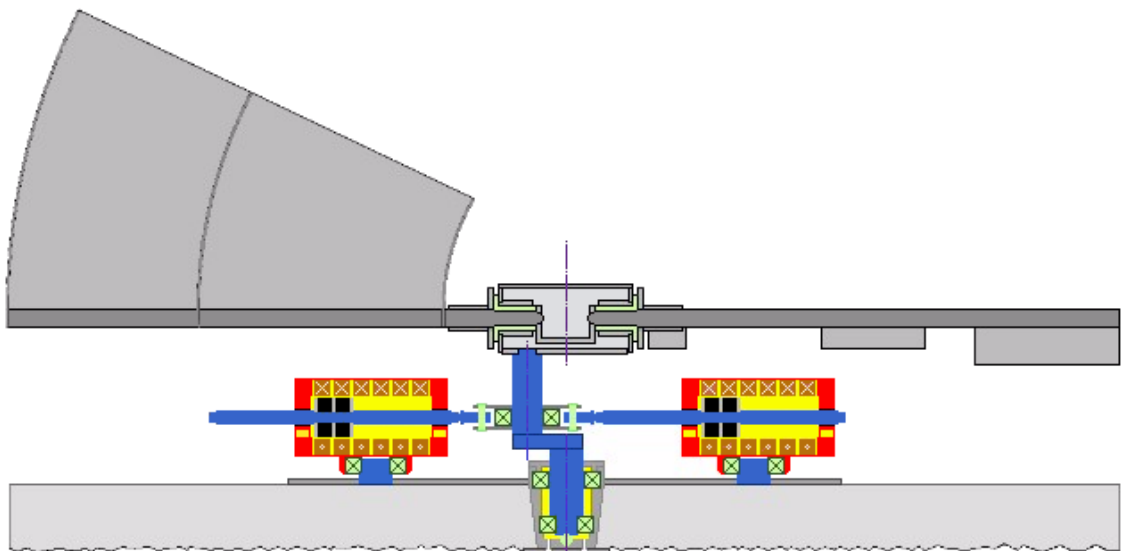

Illustration of the previous system with the SG generator, or piston pumps.

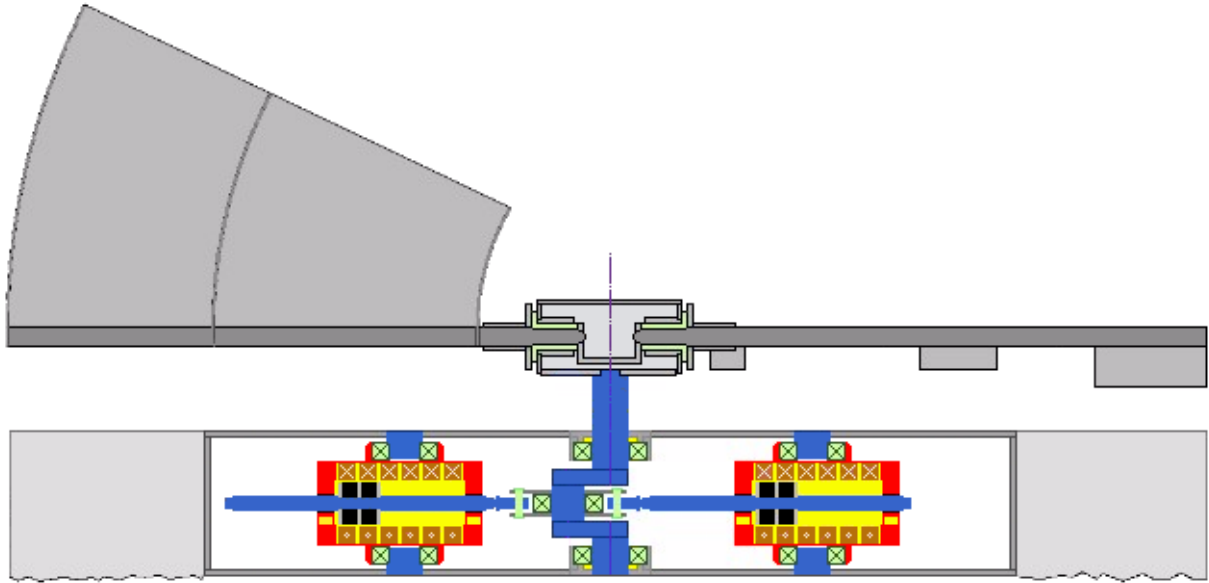
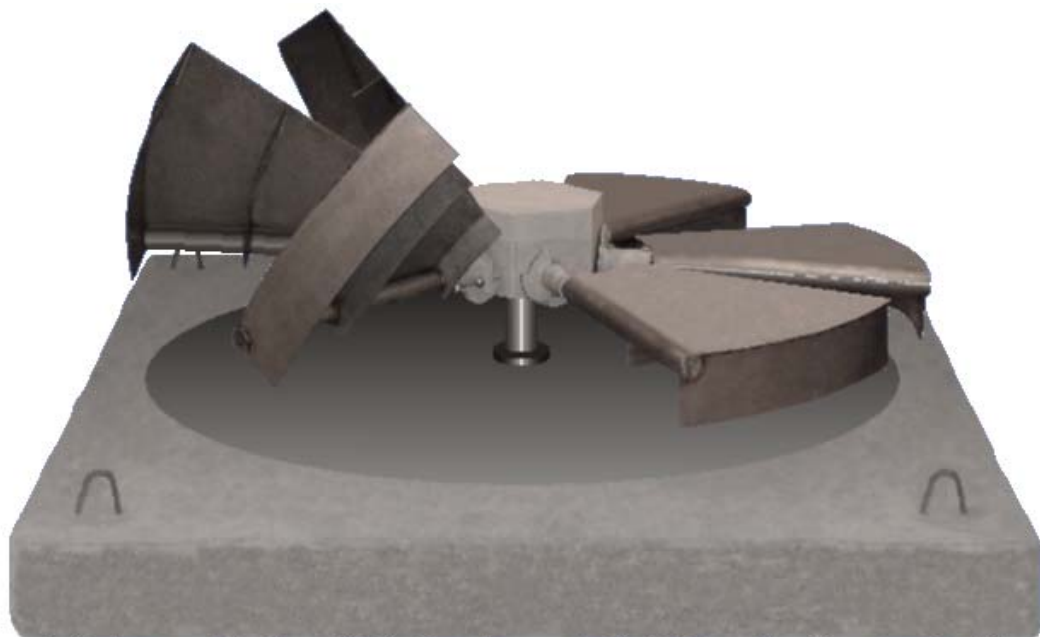

Illustration of the new system with the SG generator or (similar) piston pumps.

Regarding all mentioned, we are still opinion that for producing electricity, our SP units are nearly ideal solution for the category of “Pico” power plants, where we intend to remain on the powers up to 25 kW of electric energy. Such production as it seems can achieve far the lowest prices per kWh, which are much lower than the current lowest price. Finally, the latest calculations shows that we will be in this year able to deliver SP units equipped with a submersible SG generators with power of 20 kW, which will be, on the basis of amortization period of 20 years, able to produce electric energy at a price of only 0.0075 EUR per kWh. Comparing our price (achieved with our SP devices) with prices for kWh received from photo cells (1,4 EUR to 12 EUR for kWh) or even with prices for electricity from larger Windmills (2 EUR to 35 EUR for kWh), we can recognize more hundred times larger difference among all other alternative energy sources.



Even more interesting is comparison of prices of electric energy received from power grid, which in developed world vary between 0,06 and 0,12 EUR for kWh. **By that, we find out that the price of energy, which is obtained by the SP devices, is still 6 to 8 times lower, than electricity from the grid and represents the lowest price for gained ecologically cleanest energy in the World.**

THE POSSIBILITY OF CONSTRUCTION OF MEDIUM AND LARGE ENERGY FACILITIES USING SG UNITS CONNECTED IN COLUMNS

Although we have mentioned in the current text that smaller power plants for individual use and power of 20 to 25 kW are the most appropriate form of SG units, additional measurements and calculations indicate that there is a possibility of building a substantially larger and more powerful energy plants which would be assembled from 10, 20 or even 50 smaller SG units which are placed in the bottom of a medium-sized river – one by one or even in the more columns.

In this moment a big problem is even to imagine 250 or 300 meters long banks of the river in which practically anything is not to be detectable but at the bottom of the river are placed two or three columns assembled from 50 or 60 SG units, whose output voltage cables have been connected to more small or one large inverter unit, which convert generated electricity and connect it to the nearest power grid.

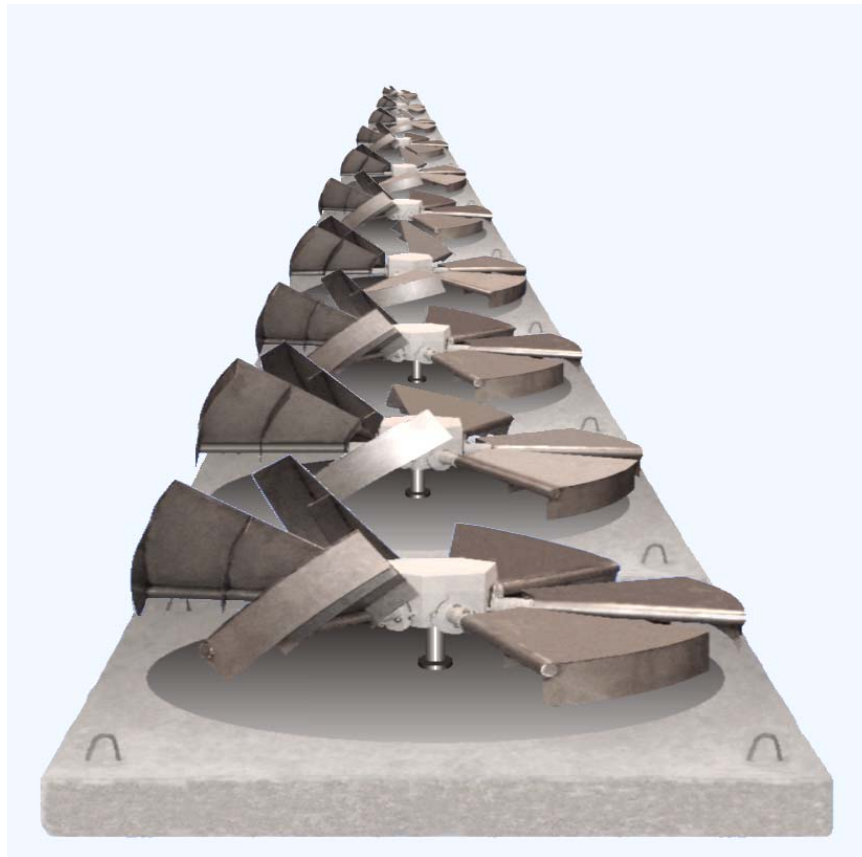

View of smaller SG power column installation with approx. 250 kW of power (at water speed of 2.8 m/sec.) and in total length of ca. 80 meters.

Approximate investment cost of such installations still don't exceed 1 EUR for each 1 W of received power, what is 2.2 times cheaper than the necessary investment for small hydro power (without major artificial lake) and 4 to 15 times cheaper than medium-sized hydro power plants with an artificial lake. For the reader who is not familiar with the actual powers of most European hydro energy sources: It is to be noted that the actual power of hundreds of plants are not so large as it is generally thought. For example, the average installed power plants in GORENJSKE ELEKTRARNE in Slovenia is not significantly exceed 450 kW of installed power, and some of them are very small: (HE Cerklje - 90 kW, HE Kranjska Gora - 152 kW, HE Rudno - 175 kW, HE Kokra - 228 kW ; HE Skofja arc - 282 kW, HE Standard - 200 kW, HE Davča - 320 kW, HE Sorica - 140 kW, HE Zvirče - 370 kW and HE Suhelj - 160 kW), and only some of their power plants are exceeding 1 MW of installed power.

POSSIBILITY FOR DESIGNING OF HIGHLY EFFICIENT SYSTEMS FOR DEEP WATER, OR EVEN FOR TIDAL POWER

Relatively negative hydrodynamic effect of most rivers is that speed of water at the bottom is the lowest. Therefore, we have the first prototypes upgraded with the possibility of correction of this phenomenon in the sense that on the same driving axle – but higher - we can place additional propelling turbine.

SP or SG unit for very slow river flow or Tidal

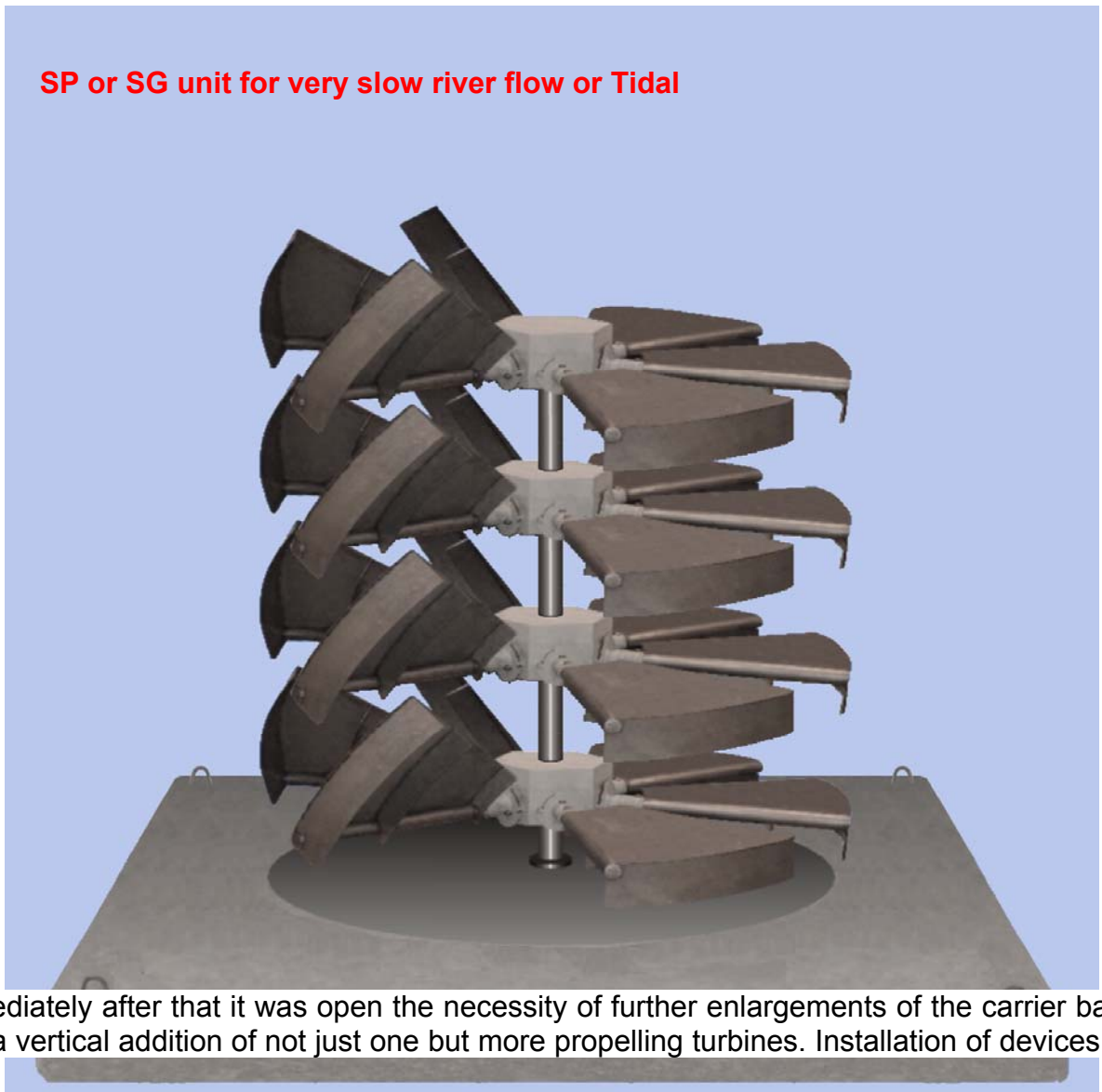

Immediately after that it was open the necessity of further enlargements of the carrier base and a vertical addition of not just one but more propelling turbines. Installation of devices as

shown at the figure above is offering the cheapest, and the most effective solution to generate electricity from slow water currents in rivers and even Tidal streams in sea water.

The picture shows the double (reverse) layout of the pairs of wings, is suitable for installation where water is very slow and (with much smaller power) continue to operate even at a minimum depth of water flow, which does not substantially exceed a depth of 1.3 m. SP units as described were developed mainly for irrigation systems operating in very shallow water (pumping station on river Savinja near Celje).

In the classical known calculations present on pages 9 and 10 of this brochure we perceive very important physical facts that were obviously missed out even by genius Bernoulli: If he separated his calculations on incompressible, and compressible media, remains the fact that running water in the stream is considered as incompressible media. In this case, we find almost unsolvable problem of Physics that on transverse placed barrier are not pressing only water molecules that touches it but (due to incompressibility), very long straight-line column of water molecules from the direction of water flow. So, known calculations without total mass of (incompressible) water “column” pressuring on the barrier are not taking into account. This is in direct conflict with all basic principles of Newtonian mechanics!

On pages 9 and 10 present calculations could not introduce to readers of this brochure nearly endlessly big number of possibilities for assembling of SP and SG units to different slow water streams. One, very interesting is:

THE WALL

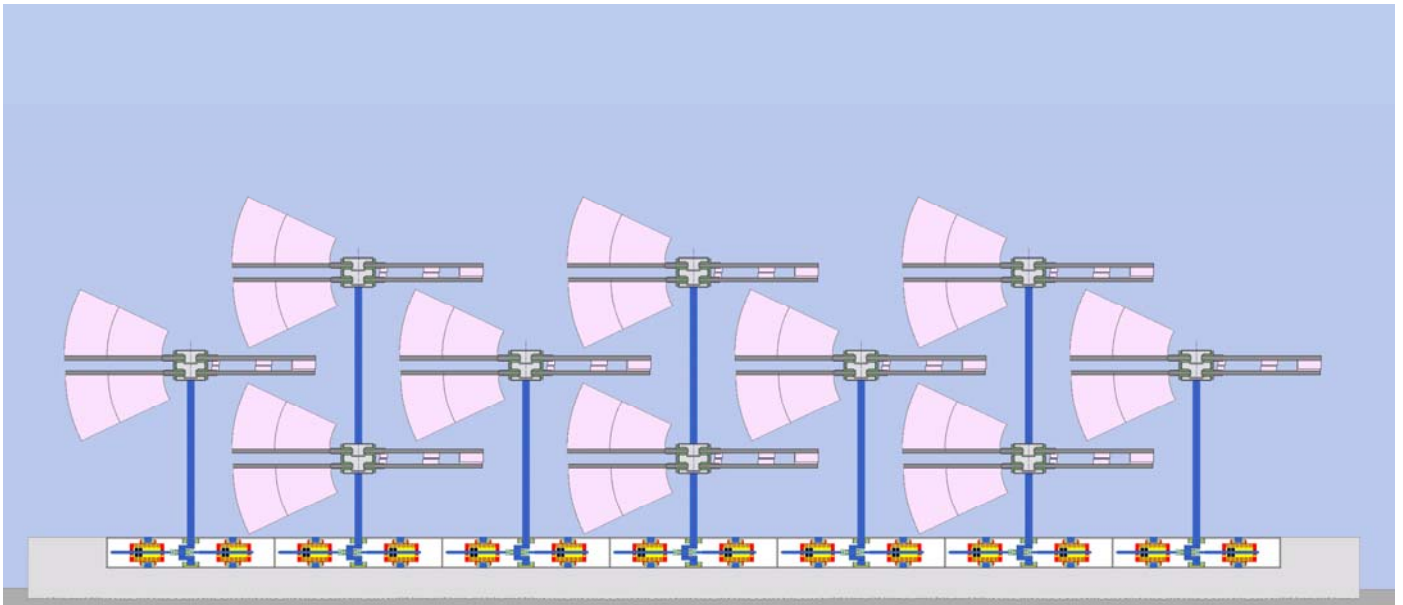

On illustration presented "THE WALL" have to be assembled from 7, 9 or couple of moiré SP or even SG units, forming transverse placed barrier and by speed of water stream from 2,5 m/second it can easily deliver 1 MW of mechanical or electric power. Such design is in slow but larger rivers nearly ideal - as far for TIDAL Power stations in see water.

WHAT, HOW AND HOW MUCH FOR ELECTRIC POWER ?

In the past few years we reached many public misconceptions concerning the known and alternative energy sources and their real prices and effects. Let's see what and how much is realistic and what we actually get:

1. "PHOTOVOLTAICS" (Photo cell installations)

In Slovenia (unlike Saudi Arabia) within four months of summer, during a few hours a day present value of solar energy does not exceed 550 watts per square meter. Considering that the efficiency of photo cell elements was up to these days around 10%, today (II generation) rises up to 30%, and over the decade will allegedly reach up to 45%, we get the

fact that for all 365 days (and nights) a year only for permanent industrial and public use in city of Ljubljana we need surface covered with photo panels larger than 1/6 of whole country of Slovenia! So, even if the current price from 5 EUR per Wp fall below 2 EUR per Wp, all together would be without any importance. Investments required per unit of energy are extremely high - eight times larger than is necessary to pay for Thermo Power plant. When we add the cost for the carriers for solar cell panels, costs for enormous capacity of inverters and batteries (for the times when it is night or when rain clouds are present), realistic and the lowest investment cost per kW for the installation of at least 1 to 10 kW can not be lower than 12.000 EUR per each kW of Power and that is economically totally unacceptable.

Investment needed for each kW of actually gained power: approx. 12.500 EUR
The price obtained for each kWh of energy: approximately 0,5 to 1,2 EUR

2. WINDMILL

Together with heating costs in winter months, Slovenian householder uses about 137 kWh of energy per day. For so large consumption, such "alternative" energy source is not any kind of serious alternative. For example, constant wind speeds in range of 11 to 15 m/second in Slovenia are very rare and the same time, manufacturers and suppliers of Windmills are promising us that each kW of power they can deliver at a price of just 1,65 EUR for 1 W of power. Of course, while forgetting to tell us that these are just theoretical figures which indicate power installed on Windmill – but just in the case of sufficient wind speed. By slower wind speed, received Power radically reduces. Practical experience from around the world without exception, confirmed that in the longer term from Windmills we are receiving only 20% of installed power and in some cases (the second largest "wind farm" in England) has an average of just 7.8% of gained power - in relation to installed. This means that when ordering Windmills a new owner must order and install approximately five time larger capacity to receive planed power! So, credible figure of investments needed for realistically received each kW of power exceeds 8.000 EUR. Real operating cost for a kW of electrical power will depend on the size of wind turbines and local wind conditions and can vary from 0,5 and up to 4 EUR per kWh. Regarding all mentioned, it seems to be that "Photovoltaics" and the Windmills are not exactly "alternative" energy sources and their proper name should be "temporary, very expensive and additional" energy sources – because they could not be any longer time alternative to existing energy needs or prices of electricity.

Investment needed for each kW of actually gained power: approx. 8.500 EUR
The price obtained for each kWh of energy: approximately 0,5 to 2 EUR

3. THERMO POWER PLANTS

The most recent data available to us is current price of thermal power block VI of Power Plant Šoštanj (in Slovenia) - 1,000.000.000 EUR. With that investment, 600 MW of Power can be generated, so investment will not exceed 1.700 EUR for each kW installed. This almost ideal investment costs significantly deteriorate the fact that this plant will annually "burn" a huge amount of coal, and create huge atmospheric pollutants what significantly

raise the price obtained for each kWh of energy exploitation. Still, the prices of energy gain in relation to the above "alternative" sources, are not comparable.

Investment needed for each kW of actually gained power: approx. 1.700 EUR
The price obtained for each kWh of energy: approximately 0,06 to 0,08 EUR

4. HYDRO POWER PLANTS

According to official figures, the total potential of Slovenian rivers reaches 19.400 GWh per year. Economically convenient for use are about 9.000 GWh per year but Slovenia is currently using only 3.970 GWh. A problem regarding larger exploitation is in construction of dams and reservoirs. For example, only in 100 km long river Mura (through Slovenia) with about 100 meters of total high difference, in theory can be built at least 10 or 11 relatively large hydro power stations - instead of the current and relatively small Hydro Power Plant Ceršak, which is giving only 662 kW of power. However, the configuration of terrain around Mura river is so flat that such impact on the environment, would never arise.

Very expensive and technically very demanding building of dams are major causes of such a low rate of use for so great a renewable energy source such is hydro power. Also the costs of each new facility are very difficult to predict because it depends largely on the configuration of the ground and the existing water source. However, investment costs are significantly higher than that of thermal power plants, and (depending on the size and strength) in range from 2,200 EUR to 6,000 EUR (or even much more) for each kW of gained power. However, after building Hydro Power plant, additional costs are almost zero during many years of operation.

Investment needed for each kW of actually gained power: approx. 2.200 to 6.000 EUR
The price obtained for each kWh of energy: approximately 0,03 to 0,05 EUR

5. SG UNITS IN COLUMNS PLACED ON THE BOTTOM OF RIVERS

If for a moment we forget unusual view of more SG units placed on narrow area of the river bottom, (which are, during operation not detectable from the river banks), we must consider also the full environmental acceptability of such installation – regarding a very slow rotation (only ca. 3 revolutions per minute!). It is also important to know that after all previous experiences we know that such installation do not cause any serious effects on the water body with exception of temporary and slightly reduction of water speed on its bottom and small speed incensement of the water in the top layer. But, some 10 meters after SP installation comes re-alignment of water velocity in different layers.

Comparing the whole production costs of up to 19.000 EUR per single SG unit and after building approximately 50 peaces to reach 1 MW of constant power, an investment cost between 850.000 and 950.000 EUR is to be considered. This is nearly three times lower investment cost than we need for small hydro power plant with the same output power and more than eight times lower that are investments required to install wind turbines with similar capacity. The price per reached kWh is even not to be compared!

Investment needed for each kW of actually gained power: approx. 950 EUR
The price obtained for each kWh of energy: approximately 0,01 to 0,015 EUR

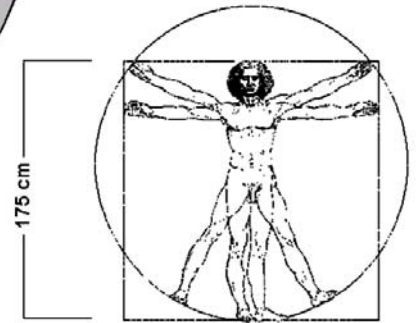
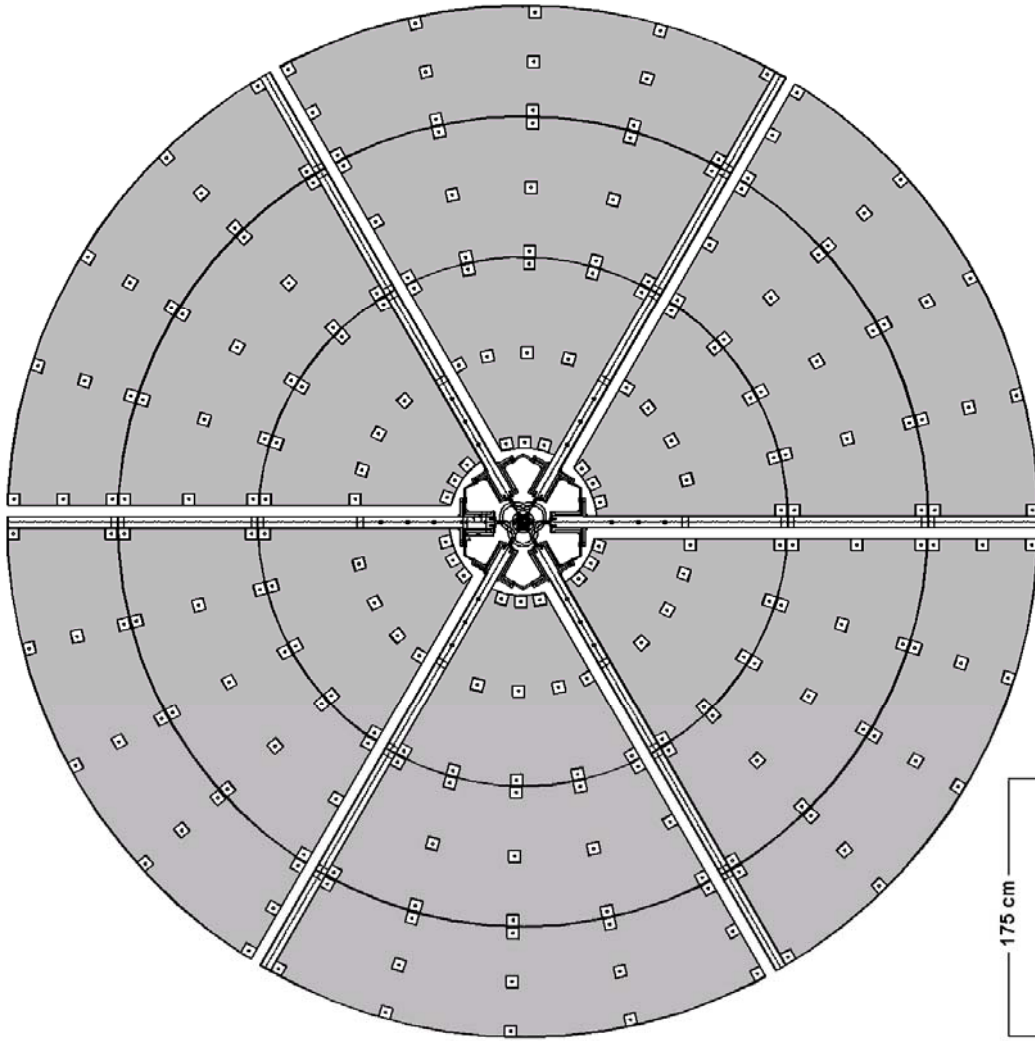

By dimensions comparable drawings of the biggest serial SP unit - SP 70 with rotor diameter of 7 m.

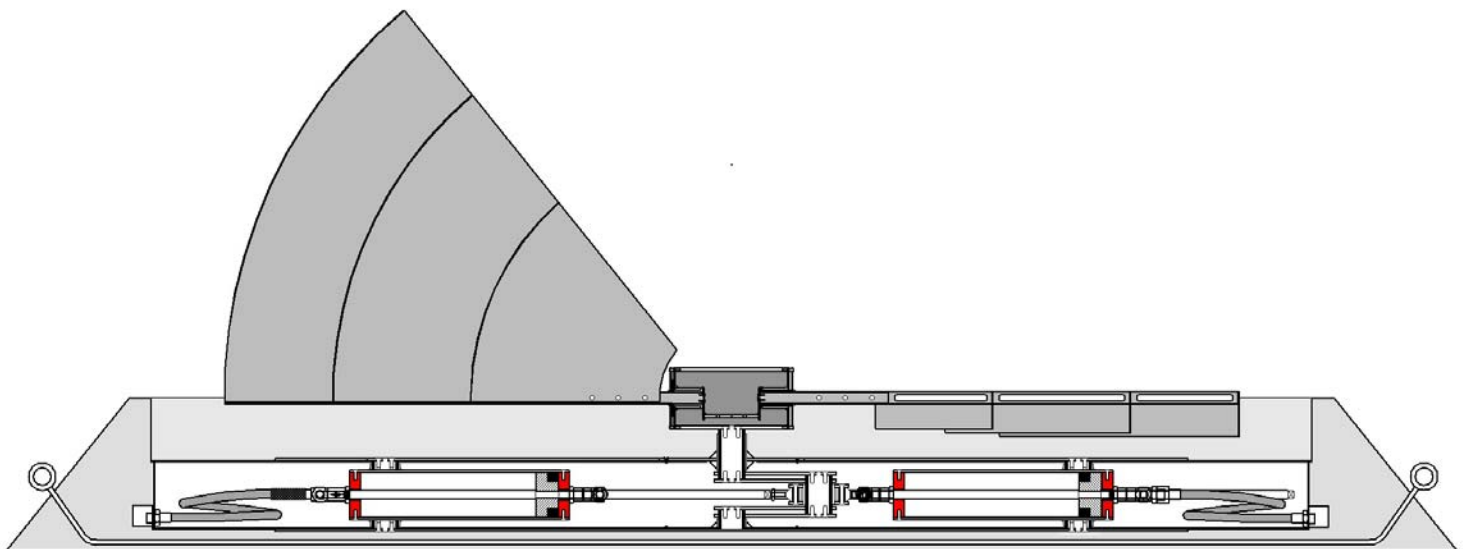

Single Propelling Turbine **Power** by different speeds of water stream:

Model turbine:	SP 1,6 m	SP 2,4 m	SP 3,6 m	SP 5,5 m	SP 7 m
Minimal water depth:	1,1 m	1,35 m	2,4 m	3,3 m	3,8 m
Stream speed 1 m/sec	100 W	350 W	820 W	1,6 kW	3 kW
Stream speed 1,5 m/sec	320 W	1,1 kW	2.8 kW	6 kW	11 kW
Stream speed 2 m/sec	700 W	2 kW	5 kW	11 kW	26 kW
Stream speed 2,5 m/sec	1,3 kW	5 kW	11 kW	26 kW	43 kW
Stream speed 3 m/sec	2,5 kW	9 kW	21 kW	50 kW	82 kW
Stream speed 3,5 m/sec	5 kW	15 kW	35 kW	81 kW	139 kW
Stream speed 4 m/sec	7 kW	24 kW	53 kW	125 kW	208 kW

For example, only at the bottom of river Mura in Slovenia we are able to place between 300 and 600 SG groups of units of 1 MW of real power and in Slovenian rivers Drava, Sava, and even several smaller rivers, at least twice so much. On that way we are coming to the possibility of obtaining extremely cheap energy, which would broadcast in exploitation in electricity grid with a price that exceeded 0,012 EUR per kWh. Exactly speaking, this means also the following: Instead of more than 1,000.000.000 EUR for VI block of a new power plant in Šoštanj, SG units in the river Mura could gain the capacity (350 MW) of electricity with significantly lower investment, all funds would stay at home and further recruited many unemployed workers.

I am expecting that in the next 4 to 5 years - spending lowest possible investment sources, in Slovenia, we can build new SG power units for the constant production of 1.300 MW of the world cheapest and cleanest electricity. For the most of the medium or high developed countries of the world relations are very similar or, existing exploitation of hydropower sources, can be for up to 200 % increased – based on very low investments and ideal ecological way.

IZUMI
 Markovic in ostali d.n.o.,
 Ljubljana
 Vladimir Markovic

PS: More data, animations and movies you can get on <http://www.izumi.si>

